

HARRIS 222 AMPLIFIER

Details and Modifications

Ron Marosko, K5LLL

HARRIS CH 11 Amp



- The Harris Channel 11 amplifier is a brother to the one used by many on 6M. It is capable of 1 KW output and uses a nominal supply voltage of 48-50 VDC.
- Thanks to Greg, K5GJ for locating a source of these amplifiers.

Channel 11 Amplifier

The amplifier comprises 4 individual modules, each with 4 power FET devices, the same as the version used on 6M. The only difference is that the gain is lower due to the higher frequency

Measurements indicate the gain of the 1 KW amplifier is about 10 dB, requiring about 100 watts of drive for 1 KW output. As channel 11 is around 200 MHz, the amplifiers are usable at 222 MHz, though with some reduction in gain and output power. It has all the safety features to make it essentially bullet proof against overdrive, high SWR and out of range supply voltages.

Single Module

- The individual modules (4 FETs) are useable also with lower drive. Removing them from the main amplifier takes away the protection, so care must be taken to keep SWR reasonably low and drive within limits. They utilize standard 50 ohm input/output impedances, making them easy to use,



Single Module Measurements

Measurements made on a single module using 51 VDC from a HP Server supply and +15V on the bias input to the board, indicate about 13 dB gain without all the power splitting and combining, giving over 200 W output with 10 watts drive and about 9 A from the power source. In excess of 300 W has been seen with more drive, though no real characterization has been yet done with accurate test equipment. Idling current is 2A or about 0.5A per FET. Individual pots are available to adjust each device. The table below gives measurement details but accuracy is not optimum; it is difficult to make accurate measurements less than 20 watts using a 100 watt slug in the Bird meter.

Input SWR measured about 1.7:1. Attempts to correct this for 222 MHz will be done when time permits.

Input -W	Output -W	Current – A	Gain – dB
0	0	2.0	0
4	115	6.0	14.6
6	150	6.8	14.0
8	185	8.0	13.65
10	215	8.6	13.3
12	240	9.1	13.0
14	260	9.5	12.7
17	280	9.8	12.2

Measurements on Single Module at 222 MHz

(subject to accuracy and readability of test equipment)

Module Cooling

- Cooling must be provided as with the main amplifier. There are fans available for less than \$5 (Micro Center) that can be mounted directly to each module's heat sink with 4 sheet metal screws, though not sure that this is considered an approved method. This appears to be sufficient for normal amateur CW/SSB usage under an intermittent operation



Computer case fan and sheet metal screws

Module Cooling

- Although the fan is specified to operate from 12 VDC, it works well at 15 volts, drawing only about 120 ma. This allows use of the bias supply for the fan. It is so quiet, you won't hear it over the HP Server power supply fan.



Fan mounted in place on the module heatsink

Relay Switching

- To build a stand-alone amplifier, a relay is required for the input and the output. Although dual pole dual throw relays are available, separate relays on input and output is a usable configuration. Ever wonder what you can do with those 24 VDC relays that are available for reasonable prices at flea markets? A pair of those with the coils hooked in series work well for this application with a 48-50 volt supply.

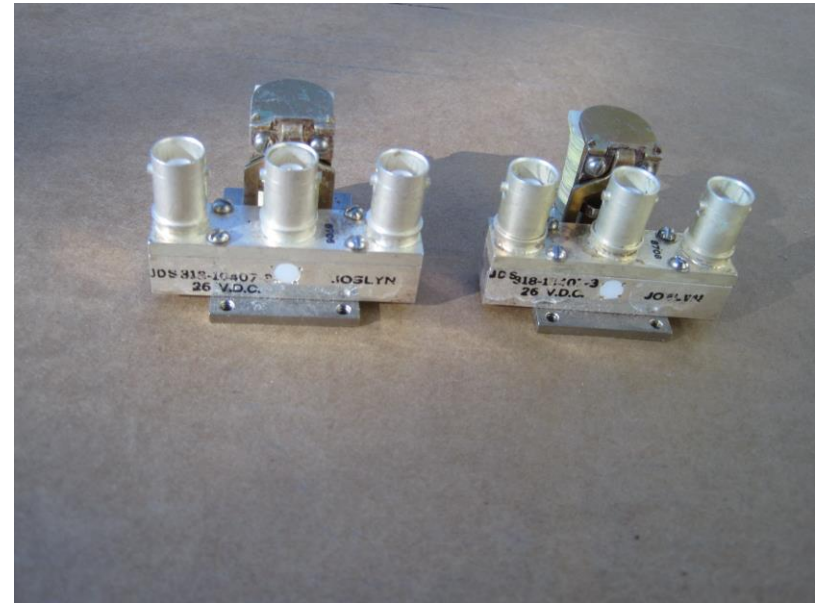

Surplus BNC 26V relays

Additional Circuitry

- In order to use one of these modules to boost the output of your DEMI or other transverter, a bias supply (+15 VDC) is necessary as well as keying circuitry. Regulating a 15 volt output (250 ma) from the 50 VDC is a simple matter as is keying of the bias and relays from a standard ground input keying line.

Control Circuit

- Power MOSFETs are very useful devices that simplify design of voltage regulators and switching circuitry. A regulated 15V supply requires only an N channel power MOSFET, a TL431A programmable zener and a few resistors. Current capability is limited only by the heat generated by the voltage drop times the current as with any linear regulator. A P channel MOSFET simplifies power switching of the bias voltage using a ground active drive.

Control Circuitry

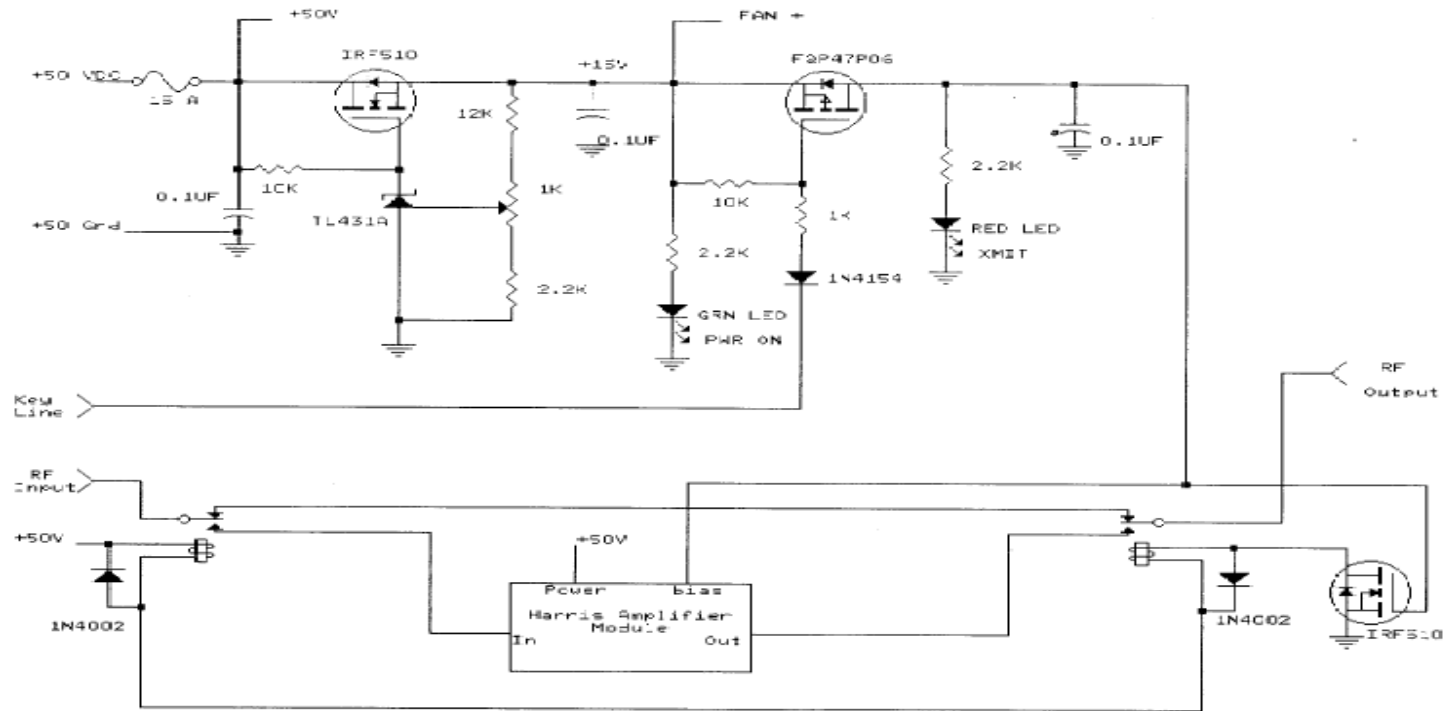

K5LL - RMG	
Title	Harris Amplifier Control
Size	Document Number
A	REV
Date:	February 22 1978

Finished Amplifier



Finished Amplifier



Results

The finished amplifier outputs 250 watts easily with about 15 watts of drive, even with input SWR of 1.7:1. This is expected to be lowered once a variable capacitor is substituted for the fixed capacitor on the input. Possibly more output may be achieved by adjustment of the tuning stubs on the outputs as it is operating 10% above its design frequency.

This would make a nice addition to a FT736 or DEMI transverter with their output capability of about 25 watts.

Output purity has not yet been checked with a spectrum analyzer, it may require a low pass filter to ensure all spurs are >30 dB down.

If interested, check with Greg, K5GJ for availability.